

# Guidance relating to the Construction and Use of Citadels in Waters Affected by Somalia Piracy – July 2011

## Introduction

Somali-based piracy continues to pose a significant threat to maritime traffic in the High Risk Area (an area bounded by Suez and the Strait of Hormuz to the North, 10°S and 78°E as defined in the Best Management Practices). With the increasing incidence of attacks, there has been a corresponding increase in defensive measures applied by vessels – one of the measures is the retreat to a 'Citadel'.

A Citadel as defined in BMP4 is *“A designated pre-planned area purpose built into the ship where, in the event of imminent boarding by pirates, all crew will seek protection. A Citadel is designed and constructed to resist a determined pirate trying to gain entry for a fixed period of time.”*

Since January 2010 there have been 26 cases where pirates have actually boarded vessels, but have been unable to take control because the vessels crew have all successfully sought refuge in a pre-planned Citadel; however there have also been 5 cases where Citadels have been breached - these may be attributed to a number of factors including poor construction and location of the Citadel

With the use of Citadels increasing, the pirates have similarly gained experience in defeating a Citadel – this includes use of weapons, ship board tools, and attempts to smoke out the crew and/or set fire to the vessel.

Initially the Citadel concept was restricted to the Gulf of Aden where a rapid response by the Military/Naval forces was considered possible. In these cases the crew generally retreated to a locked Engine Room and thence blacked out the vessel to await assistance. However, more recently attacks and illegal boardings have occurred much further out in the Indian Ocean, (including the Somali Basin and Arabian Sea). In these cases the possibility of a response by Military/Naval Assets is more remote, and with the paramount consideration being the safety of the crew, it becomes essential that any use of a Citadel is properly planned with all factors being considered.

Although the Citadel may be considered the final safe haven, and should protect against determined intrusion, including a limited ballistic attack, the Citadel rationale should be part of a **layered level of security**, where approaches to the Citadel are effectively protected. The predetermined time period will be determined by a Risk Assessment, dependent upon the vessels trading patterns, construction, and needs.

## Aim

Should the Ship Owner / Operator, following a thorough Risk Assessment, and having exhausted all other measures of self protection as detailed in BMP4, conclude that a Citadel is required, this Guidance describes the construction and use of a Citadel, in order to provide effective protection against determined intrusion.

These Guidelines do not attempt to recommend or endorse the construction/use of a Citadel, but aim to present the relevant facts to enable the Ship Owner / Operator to reach a reasoned conclusion as to whether or not to utilise a Citadel.

## Experience to Date

Although the number of cases of Citadel use is limited, experience to date has revealed the following important information on their use;

- Once the pirates manage to board a vessel they will in general try to make their way directly to the Bridge – usually accommodation doors are locked and the external stairways offer an easier route. Any delaying tactics by blocking access is useful since it will give the vessels crew more time to secure the Citadel and its approaches.
- Pirates cannot operate a vessel without the crew.
- Once access to the Bridge has been gained, the pirates will then systematically search through each cabin and locked compartment gaining access by utilising small arms fire or any other equipment that they may find on board such as crowbars, fire axes etc.
- Attempts have been made to smoke out the crew from a Citadel, by setting fire to the Bridge and/or accommodation.
- Pirates have been known to force hinges, and to use mechanical tools such as disk cutters (if found on board), to breach compartments. They have also attempted to pull off doors.
- Vessels which have locked all doors in the accommodation, and which have effectively secured the inner stairwell doors leading to each deck on board, have in the past generally been successful in delaying the pirates to such an extent that the pirates have been frustrated and departed, or that the delaying tactic has enabled the Naval/Military forces to be given sufficient time to respond and intervene.
- Pirates have been known in the past to use ruse and trickery in an attempt to coerce the crew into voluntarily exiting the citadel.

## Risk Assessment determining whether to utilise a Citadel

Any decision to utilise a Citadel should be based upon a thorough Risk Assessment, which should be conducted on a ship-by-ship basis. The assessment should not be fleet or type specific since most vessels differ to some extent. There should be clear guidance and advice given by Management to Masters and senior officers carrying out the Risk Assessment on the location, construction, and other necessary requirements of a citadel. Management should also have procedures in place on the use of citadels however, the final decision to use or not to use the citadel should be on the Master of the vessel depending on the circumstances prevailing at that time.

The Risk Assessment should consider but is not limited to ;

- Physical size, speed, and vulnerability of the vessel.
- The ability to meet the Citadel criteria (as set out below).
- Geographical trading area including consideration that the Naval/Military forces may not be able to offer assistance.
- That all other avenues of self protection based upon Best Management Practices have been effectively implemented.
- The potential consequences of an escalation of the situation.

## Citadel Criteria

If the Risk Assessment determines that a Citadel is required, consideration should now be given to the following;

- Location of the Citadel

- Time frame for Citadel survivability
- Construction of the Citadel
- Use and operation of the Citadel
- Naval/Military forces response / assistance

### **Citadel Location**

Vessels differ greatly in size and construction, therefore it is not possible to consider all potential locations of a Citadel within this document. However the following factors should be considered;

- The location should be difficult for pirates to locate. This may be influenced by the size and layout of the vessel. It is also helpful if the entrance to the citadel is camouflaged.
- The compartment should be able to be fully secured from all entrances including hatches and vents. It is important that all six sides of the compartment are taken into account when considering the security and potential vulnerability of a space.
- As a minimum the compartment must have the ability to deny the pirates access to the vessel's propulsion. Ideally, full control of the propulsion and the vessels essential systems, together with the ability to navigate, should be possible from the compartment. (See also section on equipment, page 5).
- Accessibility to the compartment, and time taken in order for it to be effectively secured.
- In some cases the construction of the vessel may dictate that the Citadel requires a means of escape. If so, then this should be well concealed and the vessel should have detailed procedures as to its intended use in a Citadel scenario.
- Habitability of the compartment being suitable for the vessels crew, including size and ventilation.
- The thickness and the fire retarding nature of the six sides of the citadel should be kept in mind while determining the location of the citadel including, if necessary, the ability to easily reinforce this.

### **Survivability Time Frame**

The Citadel should be able to survive for a given time span. This time span will depend upon intended use, and is a fundamental consideration at the planning stage.

- A short time span survivability may be considered should the vessel require a Citadel in the IRTC/Gulf of Aden where there is a higher concentration of Naval/Military forces and therefore more likelihood of rapid assistance being available.
- A longer time span survivability should be considered for a Citadel in the Indian Ocean and Somali basin where there is a lower probability of a Naval/Military forces response due to a lower concentration of available assistance.
- Hardening and securing accesses to the actual Citadel is an important delaying tactic and gives an increased time of survivability. Stronger security of the doors outside the Citadel itself, potentially means the longer the pirates will take in breaching them, and thus increasing the possibility that they may give up the attempt to hijack the vessel.
- All tools and equipment that could assist the pirates in breaching defences should be locked away.

### **Citadel Construction**

Materials which are currently used to construct doors on board ships offer little in the way of a determined physical assault with the possible exception of water tight doors, and none against a ballistic assault such as with an AK47. Locks can, in general, be easily overcome, and hinges can be removed. Doors which are not watertight can be susceptible to accelerants such as gasoline leaking through. Similarly, the thickness of bulkheads within the superstructure of a vessel, are not resistant to small arms fire such as from an AK47. It is therefore important to consider additional protection both for the Citadel itself and the approaches to it, which will make it much more difficult for pirates to gain access. If the modifications involve substantial

construction changes then the vessel classification society should be consulted. Factors to consider for the construction of the Citadel include;

- Ensuring that all access to the Citadel and the approaches are secure against a sustained physical attack. This includes doors, locks, hatches, portholes / windows and ventilation grilles.
- Pirates have been known to attempt to gain access to Citadels by forcing locks, by removal of hinges and by pulling off a door utilising ships tools. Hinges to any door should be internal, and the door itself should provide a smooth external surface in order to prevent the pirates from taking the opportunity to attach any tools to pull the door off. This may have the added advantage of offering a camouflaged entrance.
- In light of the pirates having been known in the past to try and smoke out the crew, ventilation of the compartment should be considered. In this respect the ventilation should be from a stand-alone power supply, and should provide adequate ventilation for the ships entire crew particularly if Citadel procedures involve the vessel “blacking out”. The inlet for this ventilation should, where possible , be concealed.
- Where a compartment is not watertight, and may be susceptible to accelerants such as gasoline, the use of a simple plastic sealant may negate this threat.
- A means of fire suppression within the Citadel is considered as essential to protect the crew. Portable extinguishers may offer the simplest solution but there must be sufficient available to deal with the assessed threat.
- Dependent upon the actual location of the Citadel, if the compartment is protected by a toxic fixed fire fighting system, then it may be advisable to have a means in place to temporarily isolate the system from the Citadel itself. Another consideration might be to ensure that the Citadel has the ability to activate a fixed fire fighting system, such as a water fog fire suppression system, to protect both the Engine Room and the accommodation.
- Doors, bulkheads, and glazing may be given additional protection against an attack with weapons. The materials used should be “ballistic resistant” to an internationally recognised Standard. The more common ballistic standards are discussed in the Annex to this document.

## Materials

Ballistic resistant materials are sometimes incorrectly called "bullet-proof" materials. In general materials are not bullet-proof, but only provide protection against a certain type of firearm for a certain range from which the weapon is discharged, and for a defined period of time. It is therefore important that the intended material is matched with the correct ballistic standard for the intended use.

The type and thickness of the materials used in a Citadel or its approaches will very much depend upon the level of protection that is required and if it's required to be ballistic resistant or not, for which specialist advice would be required. The advice here should mention that the thickness of the material will be such as to defeat a typically an AK47, utilising 7.62mm ammunition. It should be noted that non-ballistic materials will generally be thicker, and thus heavier, although will likely be far cheaper. On the other hand, a ballistic solution will be lighter, much thinner and in some cases portable – however costs will inevitably be higher for ballistic grade materials. Thus, in discussions with specialist advisers, the requirements for the Citadel materials should be as specific as possible.

- **Ballistic resistant doors** - These are specifically designed to provide ballistic protection, may be supplied in either wood or steel, and usually come as a complete unit consisting of both door and door frame. It can be seen therefore that careful consideration is required as to fitting a complete unit, since strength of the adjacent bulkhead structure needs to be taken into consideration.

- **Ballistic resistant panels** - Ballistic resistant panels may be straight steel plate, a composite type consisting of an aggregate between two steel plates, a ceramic composite, or a fibreglass composite material. In general the steel panels will be cheaper but weigh considerably more than other options. They are also more cumbersome to fit, but both composites and fibreglass, although thicker, are easier to work with and may be cut to size in situ, (thus offering a realistic option for existing ships to modify a compartment to their requirements. As with glazing and doors, the panels should be certified to a certain ballistic standard, this being dependent upon identified needs for the Citadel.
- **Bullet resistant glazing** - There are several types of bullet-resistant glazing, the most common being Laminated Glass, Acrylic, Polycarbonate, and Glass Clad Polycarbonate. It should be noted that Acrylic and Polycarbonate are only suitable for indoor use. Where this is not possible due to size, then reinforcement of the glazing with steel plate may afford an effective solution.

For all materials, it is essential to consider where they are to be used to offer the best protection – this will be where a Risk Assessment has determined the vulnerability to be.

### **Citadel Equipment**

Consideration should be given to installation of the following equipment for use within a Citadel;

- **Communications** - The provision of communications is essential to the Citadel; without guaranteed communications there can be no consideration of military intervention. The Master must be able to communicate to the outside world that he and all of the vessel's crew and personnel on board are safe. A two-way satellite communications system is recommended, powered from an independent source on board with the ability to provide communications for at least three days on an open line, as a minimum. Pirates have been known to target antenna in order to disrupt communications and therefore it is preferable to keep cabling and the antenna concealed where possible. The effectiveness of the communications should be thoroughly tested particularly with a concealed antenna arrangement.
- **Contact List** - An up-to-date list of key contact numbers should be prepared and left within the Citadel space. This should include UKMTO, MSCHOA, Company Owners, Managers, Operators and Charterers. There should be procedures in place ensuring that the list is regularly reviewed / updated as required.
- **CCTV** – The use of CCTV monitoring equipment serves several purposes. Primarily it can give the vessel's crew knowledge (and maybe reassurance), of the whereabouts and activity of pirates on board. This information can be passed to the Naval/Military forces. Additionally CCTV recordings can be used as evidence for any future prosecutions. The CCTV should have the ability to operate via a stand-alone power supply.
- **Navigational Aids** - In order to provide the ability to navigate towards a Military/Naval force, the routing of a GPS or even a slave radar feed to the Citadel may be beneficial (e.g. a feed from the VDR to a computer).
- **Medical Supplies** – Additional medical supplies over and above standard Medical equipment carried on board should be considered, together with an emergency trauma kit to assist with ballistic wounds.
- **Other Considerations**
  - **Food and Water** - Sufficient supplies of long life food and water – the standard is often stated to be sufficient for a minimum of five days, the quantity however should be based upon the time factor, and the number of crew aboard as determined by Risk Assessment.

- **Crew list** – It is recommended that a copy of the vessel's up to date crew list and all personnel on board is kept within the Citadel - this will ensure that all personnel and crew are fully accounted for in the event of a Citadel retreat being ordered by the master.
- **Grab Bag** – This may be made available with sundry essentials such as torches, spare batteries, and portable VHF Radios
- **Toilet** - When envisaging a prolonged period in a Citadel, toilet facilities become a consideration - a portable chemical toilet may be installed where no standard WC is available.
- **Bedding Material** - Blankets or sleeping bags should be provided, which in addition to their primary purpose, will provide some comfort against a metal deck.

## Use of Citadels

The intended use of the Citadel should be considered during the Risk Assessment and planning phase – the following points might be considered;

- The intended use of the Citadel may differ in varying geographic locations, for example, is the Citadel intended for use in the Gulf of Aden/IRTC area, in the wider Indian Ocean/Somali Basin, or both?
- Both the Company and the vessel should have procedures regarding the use of the Citadel in place that are fully understood by all parties. The exact time that the Citadel is to be utilised should also be carefully considered, bearing in mind that all defensive measures as per BMP4 should be adopted in order to prevent the pirates from actually getting on board in the first place. The time to utilise the Citadel could for example be; once the pirates are on board, or once a ladder has been successfully deployed and there is no way that a boarding can be prevented. Procedures should be absolutely specific in determining this point, since in turn, this will determine how long it will take a vessel to secure an effective 'lock down'.
- As the Citadel is being manned all other compartments should be locked, and all approaches to the Citadel secured. It is recommended as per BMP4 that whilst in the High Risk Area all non-essential compartments remain locked at all times when not in use to prevent any delay in securing the Citadel during an incident.
- Consideration will have to be taken as to the exact use of the Citadel should the vessel have a Security Team on board. **The Citadel will only be effective if all crew, security teams and personnel onboard embarked for the passage are secured within the Citadel.** When determining the operating instructions for a Citadel it should be borne in mind that **Military Forces will not board a vessel unless all personnel onboard are confirmed as safely secured within the Citadel.**
- The use of a password system whereby the master will only exit the Citadel upon an agreed verbal signal is recommended. The agreed password should only be exchanged via secure communications, (satellite phone), and it is recommended that the password exchange is known by both the Company and the vessel. This ensures that the Naval/Military forces can be made aware of the password(s) and equally importantly ensures that any misinformation by the pirates over the VHF can be ignored.
- If a citadel is to be considered, then it is essential that the pirates are denied access to the vessel's propulsion in order to ensure that the vessel cannot be sailed off by the pirates themselves. While it may be impossible in the majority of existing ships, it may also be considered advantageous to be able to safely maneuver and control the ship from inside the citadel. In many cases involving use of a citadel, the vessel has simply stopped and "blacked" out with the crew safely gathered inside the citadel.
- In some circumstances and following discussion with UKMTO or military authorities advantage may be gained by steaming towards the nearest responding naval vessel. This option is, in some circumstances, advocated by military authorities, but it should be preplanned and agreed by all of the relevant stakeholders (owner/manager, master, flag, charterer etc). This reflects the exceptional and unique circumstances the vessel would find itself in once the pirates had boarded. A complete lighting blackout (with the exception of the citadel) has also proven to be an effective delaying tactic.

- The importance of training if a Citadel has been utilised cannot be overestimated. The crew will need to drill exactly what to do, when to do it, and become fully familiar with their role, and the alarms / signals involved. The whole concept of a Citadel is lost if any member of the crew is left outside before the Citadel is secured. Such training may also include securing all approaches to the Citadel where applicable. In addition the training should involve personnel locking all public rooms and cabins as a further delaying tactic.
- There have been cases where the pirates have used hostages from a mothership and ordered them to attempt to gain access to the Citadel of another ship. Bearing in mind that the pirates may threaten the hostage with their life, the Company is advised to have a specific procedure in place to allow for this eventuality, and the vessel should be instructed in the appropriate response.
- The Company should have procedures in place detailing a scenario where the Naval/Military forces are unable to respond, and the actions required of the crew in this situation. These may include the following:
  - If the pirates are on board, the length of time of a stand-off should be considered. The possibility that the pirates may become increasingly desperate should be taken into account.
  - If there is reason to believe that the pirates have left the vessel, the length of time before the Citadel is opened, the number of personnel permitted to investigate, and further actions if it is discovered that the pirates are still on board, should all be considered. In this respect knowledge of any forthcoming military assistance and use of CCTV where possible may prove to be invaluable.

## **Military Considerations**

Having a Citadel does not guarantee a Naval/Military force response. The following are current requirements prior to any Naval/Military force intervention. The latest guidance may be found on the MSCHOA website – [www.mschoa.org](http://www.mschoa.org) and the NATO Shipping Centre web site [www.shipping.nato.int](http://www.shipping.nato.int)

- All of crew, security teams and personnel on board embarked for passage must be secured in the Citadel.
- The crew of the ship must have self contained, independent, two way external communications. Sole reliance on VHF communications is insufficient.
- The pirates must be denied access to propulsion.

There are other factors which determine the ability of the Naval/Military forces to respond even if the above conditions are satisfied. These include:-

- The location of the vessel that has been boarded illegally in relation to the naval vessel. In addition to any geographic limitations between the two vessels, some naval assets have a strict area of operations which are imposed upon them – they are not permitted to use force outside of this area.
- In many cases the Naval/Military force is required to have a specially trained team on board to enable an 'opposed boarding' to be conducted.
- The Naval/Military forces may have to obtain approval for an opposed boarding from the Flag State of the vessel to be boarded and from the Foreign Office for all Nationalities on board.
- Weather considerations may prohibit an opposed boarding.
- Any opposed boarding takes time to plan and requires assistance from the Owners/Ship Operators.
- Owners should have/keep ship plans available to send to the military in suitable electronic format.

## **Conclusions**

With the safety of the crew being paramount, the decision to deploy a Citadel or otherwise should take into account all known factors and be Risk Assessment based. It is important that if a Citadel is to be employed, it should be additional to, rather than a replacement for, all other self-protection measures set out in BMP 4.

The location, construction, and intended use of a Citadel must be thoroughly planned and thought through. Once in place, its use should be practised and drilled in order for all of the vessels crew to understand their roles, and to train in the time taken to ensure an effective lock down.

Somali Pirates knowledge and *modus operandi* continues to evolve over time. As their knowledge on Citadels increases, then their ability and methodology in attempting to defeat a citadel will also change, and therefore more robust protection will be required.

## Annex - Ballistic Standards

There are a number of ballistic standards available, but the following are the most common which may be considered:-

- **European Standards** - All testing for ballistic resistant doors, windows, and other materials is conducted to Euro Standard EN 1522 (the test method is EN 1523).

In addition, any security glazing testing incorporated in these materials must comply with EN 1603.

The standards define type of weapon and calibre in seven categories from pistols up to armour piercing rifles. For ballistic resistant materials the classifications are FB1 to FB7 and for glass the classifications are BR1 to BR7. There is an additional classification as to whether glass will splinter (S), or is shatterproof (NS).

### EUROPEAN BALLISTIC STANDARDS

Class	Weapon	Calibre	Bullet	Range
FB 1 / BR 1	Rifle	0.22 LR	Lead bullet, round nosed	10 metres
FB 2 / BR2	Handgun	9mm Luger	Full jacket bullet (steel), round nosed, soft core (lead)	5 metres
FB 3 / BR 3	Handgun	0.357 Magnum	Full jacket bullet (steel), cast nosed, soft core (lead)	5 metres
FB 4 / BR 4	Handgun	0.44 Rem Magnum	Full jacket bullet (steel), cast nosed, soft core (lead)	5 metres
FB 5 BR 5	Rifle	5.56 x 45mm NATO	Full jacket bullet (copper), pointed nose, soft core (lead) with steel reinforcement	10 metres

FB 6 / BR 6	Rifle	7.62 x 51mm NATO	Full jacket bullet (steel), pointed nose, soft core (lead) with steel reinforcement	10 metres
FB 7 / BR7	Rifle	7.62 x 51mm NATO	Full jacket bullet (copper), pointed nose, hard cast	10 metres

The essential difference between FB6 and FB7 is that latter uses armour piercing bullets. An AK47 would require protection to FB6/FB7 depending upon the type of ammunition being used, (armour piercing or not).

In addition European Standards EN 13123/124-1/124-2 covers materials resistance to blasts ranging from 3 to 20 kg of TNT

- **Underwriters Laboratory Standards (US)** - The ballistic standards are UL 752 and these range from Level 1 (9mm Luger) to Level 9 (0.30 Calibre – armour piercing),

The classification is similar to the European Standard

#### UNDERWRITER LABORATORIES BALLISTICS STANDARDS

Class	Weapon (e.g.)	Ammunition
Level 1	9mm Luger/Super 38 Automatic	9mm Full Metal Copper Jacket with Lead Core
Level 2	0.357 Magnum	0.357 Magnum Jacketed Lead Soft Point
Level 3	0.44 Magnum	0.44 Magnum Lead Semi-Wadcutter Gas Checked
Level 4	0.223 Remington	0.30 Calibre Rifle Lead Core Soft Point (0.30-06 calibre)
Level 5	0.308 Winchester	7.62mm rifle Lead Core Full Metal Copper Jacket, Military Ball (0.308 calibre)
Level 6	9mm Uzi	9mm Full Metal Copper Jacket with Lead Core
Level 7	M-16 / AK47	5.56mm Rifle Full Metal Copper Jacket with Lead Core (0.223 calibre)
Level 8	M-14	7.62mm Rifle Lead Core Full Metal Copper Jacket, Military Ball (0.308 calibre)
Level 9	M-2 30-06	0.30 calibre full metal jacket, armour piercing

The thickness of the materials being used will depend upon the type of material being considered and the small arms which are being defended against. Materials may be steel, kevlar, or a composite aggregate. In general the more lightweight and thinner materials will prove to be more expensive. When assessing the

level of protection required it is important to determine the suitability and effectiveness of the materials for the intended use, location, and survivability time span.

Below are examples of how a door may be strengthened to prevent pirate access

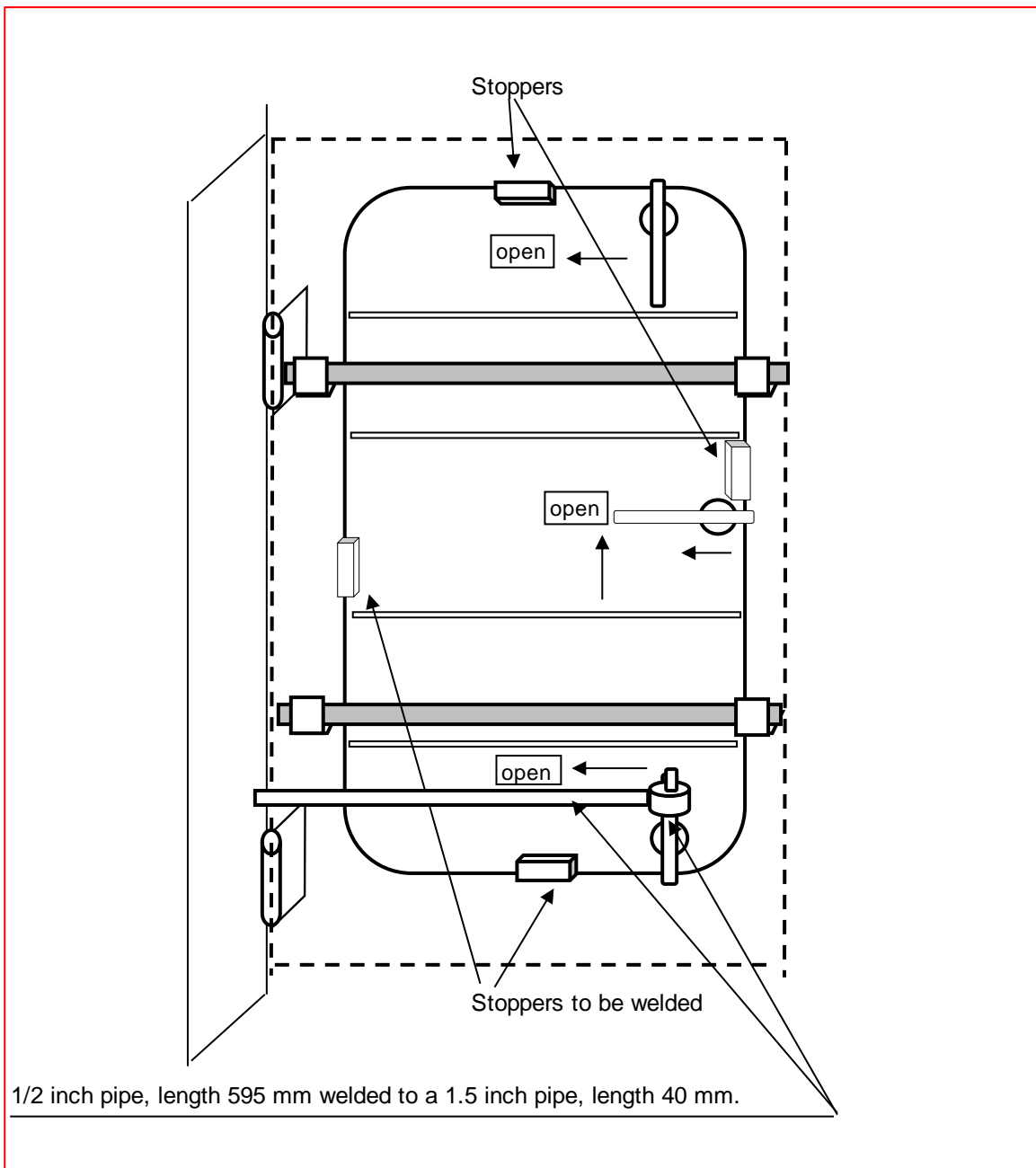

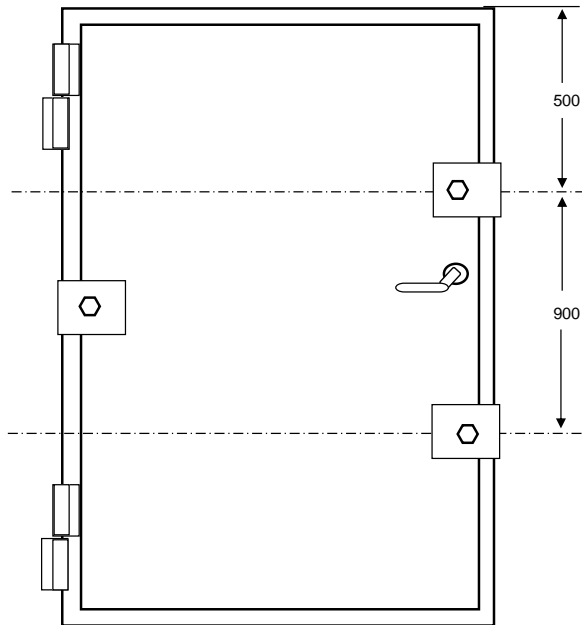
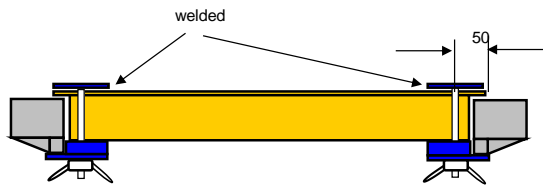

Solution 1

3pcs steel plate 100 x 100 x 4 mm  
with 12mm diameter steel bolt 110mm length, 40mm threaded, welded on plate.

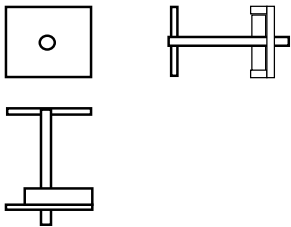

Solution 2

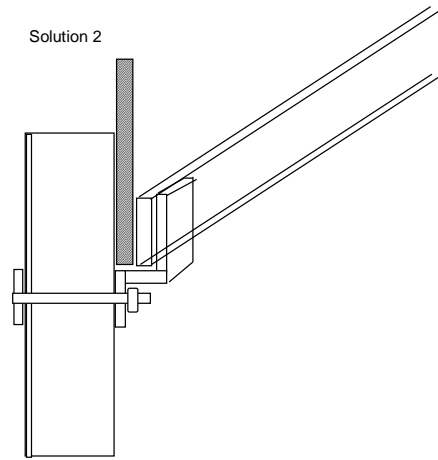



Extra strengthening on at risk doors before the citadel



As above – a further deterrent to access should the lock be breached (metal is preferred to wood)



Watertight door effectively secured